



LEON COUNTY BOARD OF COUNTY COMMISSIONERS

---

Department of Public Works

Division of Engineering Services

# Facilities Design Guidelines

**BOARD OF COUNTY COMMISSIONERS  
LEON COUNTY, FLORIDA  
DEPARTMENT OF PUBLIC WORKS  
DIVISION OF BUILDING ENGINEERING  
2209 MICCOSUKEE ROAD  
TALLAHASSEE, FL 32308  
(850) 606-1500**

Version 2023  
Published 7/07/2023

# Table of Contents

- Introduction ..... 7
- General Design Guidelines..... 7
  - Design Philosophy ..... 7
  - Sustainable Buildings ..... 8
  - General Guidelines for Architectural and Engineering Services ..... 8
- General Guidelines for Construction Services ..... 8
  - Design Guidelines for Specific Spaces..... 10
    - Custodial Closets ..... 10
    - Electrical Rooms..... 10
- Sitework ..... 10
  - General Guidelines..... 10
  - Safety and Security Provisions ..... 11
  - Temporary Services..... 11
  - Parking ..... 12
  - Demolition ..... 12
  - Earthwork..... 13
  - Pest Control ..... 13
  - Utility Work..... 13
  - Paving..... 14
  - Landscaping ..... 14
  - Landscape Design..... 15
  - Landscape Materials ..... 16
  - Stormwater Drainage Guidelines..... 16
- Concrete..... 16
  - General Requirements..... 16
  - Masonry ..... 16
  - General Requirements..... 16
- Metals ..... 17
  - General Requirements..... 17

Wood and Plastics.....	18
General Requirements.....	18
Thermal and Moisture Protection .....	18
General Requirements.....	18
Roofing.....	19
Exterior Closure Assemblies.....	20
Doors and Windows.....	21
Doors and Frames .....	21
Door Hardware .....	21
Keys and Keying .....	22
Electronic Card Access .....	22
Window Guidelines.....	22
Finishes .....	23
General Guidelines.....	23
Carpet.....	23
Carpet Quality Assurance.....	24
Carpeting Products .....	24
General Carpet Installation Guidelines .....	25
Resilient Floor Tile and Related Products .....	26
Ceramic Tile.....	27
Acoustical Ceiling Tile.....	27
Painting .....	28
Specialties .....	28
Toilet Accessories.....	28
Signage .....	29
Room Signage .....	29
Building Plaque .....	29
Fire Extinguishers.....	29
Louvers.....	30
Wall and Corner Guards.....	30
Equipment.....	30

Trash Handling Equipment.....	30
Loading Dock Equipment .....	30
Furnishings.....	30
General Guidelines.....	30
Elevators and Chair Lifts.....	31
General Guidelines.....	31
Elevator Pit & Hoistways.....	32
Elevator Mechanical Room .....	32
Elevator Maintenance and Repair .....	32
Elevator Replacement Parts.....	33
Hydraulic Elevators .....	34
Traction Elevators .....	34
Elevator Cabs .....	34
Freight Elevators .....	34
Chairlifts .....	35
Mechanical Systems.....	35
General Mechanical Guidelines .....	35
Plumbing .....	36
Water Base Fire Extinguishing Systems .....	37
Air Conditioning .....	38
Commissioning.....	38
Electrical Systems.....	38
General Guidelines.....	38
Basic Material and Methods .....	41
MC Cable.....	42
Wires and Cables.....	43
Panelboards .....	43
Switches and Receptacles.....	43
Motors and Starters.....	44
Service and Distribution.....	44
Emergency Power Supply System .....	45

Special Systems.....	46
Interior Lighting .....	46
Exterior Lighting.....	47
Drawings & Details.....	47
Electrical Rooms.....	48
Date Rooms.....	49
EV Charging Station Details.....	51
Plan View.....	51
Elevation .....	51

## Introduction

- The guidelines described in this document are for the use of architects, engineers designers, and construction personnel. They are presented to assist the professional with the design, construction, and management of building projects for Leon County, Florida, by familiarizing them with the County's construction policies and preferences.
- This manual is divided into various sections and modeled approximately after the Construction Specifications Institute (CSI) 16 division format, starting with general guidelines and site work, continuing through architectural concerns, and concluding with engineering guidelines.
- These guidelines are neither completely inclusive nor totally exclusive. If a situation develops which is contradictory to these guidelines or, if the design professional can demonstrate a more advantageous solution, the County will welcome requests for modifications.
- It is the responsibility of the Architect / Engineer to ensure compliance with all applicable codes and standards within the jurisdiction of Tallahassee and Leon County. In the event of conflict between these Guidelines and the applicable codes and standards, the codes and standards shall prevail. The Architect / Engineer shall notify the County in writing of such conflicts as soon as they are discovered.
- The design professional shall incorporate applicable portions of this guide into the project drawings and specifications unless specifically relieved of particular provisions in writing by the County.
- These guidelines shall be referenced to in the construction documents and become applicable to proposed construction.

## General Design Guidelines

### Design Philosophy

- Designs shall adhere to sound construction practice and utilize materials, methods, and equipment of proven dependability. Furthermore, designs shall specify buildings which are economical to build, operate and maintain.
- Leon County Government buildings undergo many changes during their lifetime. They, therefore, must be built from the outset with flexibility in mind with systems and structure that allow easy and economical re-configuration and functional change.
- Likewise, the sites on which they are built must be planned to allow space for future expansion. Workplace designs shall be based upon a thorough and

thoughtful analysis of workflow, work patterns and processes so that a workplace environment is created which physically and psychologically enhances work performance.

### Sustainable Buildings

- Consistent with the goals and action items in Leon County's Integrated Sustainability Action Plan, Leon County is working towards integrating sustainability into all levels of government operation.
- New construction and major renovations, as defined by Leon County, shall be designed and built to meet the current Leon County Building Sustainability Policy.

### General Guidelines for Architectural and Engineering Services

- The Architect/Engineer shall conform to the requirements specified in the latest edition of the Leon County Professional Services Guidelines.
- The Architect/Engineer shall conform to the latest editions of all codes, ordinances and regulations having jurisdiction over the project.
- The Architect/Engineer shall ensure that the requirements contained in this manual, and those contained in the Professional Services Guidelines, are communicated to all sub-consultants and that their work also conforms to them.
- Quality control is of major importance in each County construction project.
- The County expects each Architect/Engineer to routinely follow in-house quality control procedures, as are consistent with professional practice. The Architect/Engineer shall provide an up-to-date copy of his/her respective firm's in-house quality control manual on request.
- The Architect/Engineer shall include requirements in the Specifications for an orderly acceptance and turnover of the project to the County. Included in such obligations are punch lists, "record set" plans and specifications, operating and maintenance manuals, and training of County maintenance personnel.

### General Guidelines for Construction Services

- **Permits and Fees:** All costs, including building permit, use and utility connection fees shall be paid by the Contractor and costs shall be included in the project bid amount. Stormwater and other environmental fees shall be the responsibility of the County.
- All construction, renovation, repairs, or maintenance work shall be scheduled so as not to disrupt County operations at any time. The contractor, subcontractor, repairperson, or the like shall schedule and coordinate all work with the County before commencing. The contractor must provide after-hour work as required to accomplish the work and take the cost of such work into account in the preparation of bids and proposals.
- Provide temporary partitions to control dust and noise.
- Damage to County property or other property incurred by the contractor during any stage of the work shall be immediately repaired and the damaged



area restored to its original condition by the contractor at no expense to the County.

- Separate office trailers and sheds by 30 feet.
- Locate dumpsters at least 35 feet from unprotected openings or combustible buildings.
- Projects will only be certified substantially complete when the Project is ready for occupancy for its intended use when a Certificate of Occupancy has been issued and the completion certified by the County.
- The Contractor shall prepare a master construction schedule using the Critical Path Method, as outlined in the Associated General Contractors of America (AGC) publication "The Use of CPM in Construction - A Manual for General Contractors" or similar scheduling as appropriate to the Project size.
- In addition to requirements in the project specifications, Contract Closeout Documents shall include information regarding final cleaning, adjusting, Project Record Documents and manufacturers' maintenance instructions including schedules showing proper time intervals for lubrication, adjustment, calibration or checking. Contractor shall consolidate manufacturers' schedules with a single master schedule of required maintenance.
- Project Record Documents: The Contractor shall maintain on site one set of the following record documents to record actual revisions to the Work: Contract Drawings, Specifications, Addenda, Building Official Approved Documents, Change Orders and other Modifications to the contract, Approved Shop Drawings, product data, and samples. Record documents shall be stored separately from documents used for construction and kept current with construction progress. The Architect/Engineer shall monitor and verify progress in updating record documents prior to approval of Contractor's monthly Applications for Payment. The Architect/Engineer shall require submission of record drawings in electronic PDF format reflecting "record set" conditions to the County with the project Close-out Documents. This "record set" shall be adequate to provide the County with a permanent record of actual construction, to facilitate troubleshooting, and for use in future building alterations.
- HVAC Systems Manuals: The Contractor shall provide four sets of manuals to the County before a Certificate of Final Completion is issued.
- Operation and Maintenance Data. Provide detailed requirements for each of the appropriate sections of the specifications. The following checklists should be modified to suit project requirements: Roofing Manufacturers maintenance data. Elevators and hoists as per specifications. Piping systems (printed diagrams, valve tag, etc.). Control systems (printed diagrams, operating instructions, etc.). Communications (point-to-point wiring diagrams and instruction manuals, if installed by the Contractor). Fire protection systems (as per specifications). Motor control (overload heater charts). Equipment (operating instructions).

## Design Guidelines for Specific Spaces

### Custodial Closets

- Equip all toilets with changing stations.
- Toilet partitions shall be solid phenolic.
- All hardware shall be vandal resistant.
- Use bulk toilet tissue dispensers. Where work is in an existing building, use dispensers that can accept current re-fills.
- Use motion sensing flush and faucet controls.
- Receptacles shall only be installed in staff restrooms, not public restrooms.
- Install a wall mounted emergency egress light unit in each toilet room.
- Install a 4' strip centered in the wall with the water closet and lavatory. Do not install ceiling mounted luminaires.
- Refer to Division 10 for additional requirements.
- Restroom floors shall be of ceramic, porcelain, or quarry tile with dark epoxy grout. Elevated restroom floors shall have a watertight membrane, sealed to prevent seepage.
- Walls in restrooms and custodial closets shall be of ceramic tile or other special waterproof coating material, a minimum of 4 feet high.

### Electrical Rooms

- Provide signs prohibiting storage in all electrical rooms.
- In multi-floor buildings, stack electrical rooms vertically.
- Horizontally, space electric rooms not exceeding 150 feet.
- Electric rooms shall have 20% empty wall space as measured at the floor for future equipment.
- Provide an out-swung egress door with panic hardware for each electric room.
- Separate electrical rooms and data rooms by at least 12' feet.
- See Electrical room details at the end of this guide.

### Data Rooms

- See Data room details at the end of this guide.

## Sitework

### General Guidelines

- Provisions shall be made for locating a dumpster receptacle and recycling containers in an accessible site with aesthetic screening provided.
- New buildings shall have at least one loading zone to accommodate frequent moving of portable equipment to and from the building and to allow maintenance vans and personnel to have ready access to the building. Where loading docks are provided, they shall be located as close as possible to freight/passenger elevators and shall be covered.

## Safety and Security Provisions

- A six-foot high heavy woven steel wire fence on steel posts (where appearance is a consideration, a privacy type fence might be required) with gates shall be erected around the project site. No trespassing signs to meet OSHA requirements shall be specified. The fence shall be shown on the drawings. The County shall be held harmless if improper or inadequate fencing is installed by the Contractor and injury or damage results.
- The specifications shall require the Contractor and its employees, while working on the premises, to comply with the Safety Orders issued by OSHA, and any other safety, health or environmental regulations of the State of Florida having jurisdictional authority.
- The Contractor shall not load or permit any part of the work to be loaded as to endanger its safety.
- In any emergency affecting the safety of persons or property, the Contractor shall act, at his discretion, to prevent threatened damage, injury, or loss. Notification of such occurrences must be made to the County as soon as practical.
- Unless otherwise arranged in advance, the Contractor shall provide continuous utility services until the date of Substantial Completion including operation of permanent equipment and services.

## Temporary Services

- Provide temporary heating and cooling as necessary to protect the work from dampness and cold, and to dry out the building prior to millwork doors, paint, and acoustical tile installation.
- Provide temporary water necessary for construction, drinking, and testing of plumbing and mechanical systems.
- Remove temporary lines upon job completion.
- Provide temporary Sanitary Facilities and maintain in a neat and sanitary for the use of the Contractor's employees as necessary to comply with the regulations of the State Board of Health and the county and municipality.
- During construction, fire hydrants shall be installed within the specified distance of a building according to the occupancy classification to meet NFPA requirements.
- Provide temporary barriers, enclosures, shielding, and/or warning signs including audible warning devices as required for protection from hazards outside the required construction site fence, including, but not limited to, open trenches, excavations and falling objects, to comply with all OSHA requirements.
- The Contractor must remove mud and spillage from public streets without delay. Failure to clean streets promptly could result in streets being cleaned by the County at the Contractor's expense.
- All catch basins and storm drain lines in the vicinity of the site shall be protected at all times from the entry of mortar, concrete spoil, dirt, and other construction debris. The residue from the cleaning of concrete trucks,

wheelbarrows, concrete buggies, etc., must be prevented from entering the drainage system. If cleaning is done, it must be contained, and the Contractor must remove the residue from the site with other construction refuse.

- Damage to roads or other facilities resulting from Contractor's hauling, storage of materials, or other activities in connection with the Work, shall be repaired or replaced, at no expense to the County.

## Parking

- Address parking by including parking requirements as part of facility design and cost as well as restoration of displaced and disrupted parking.
- All parking spaces shall comply with applicable code regulations.
- Striping of all lots must be done using set-fast water borne traffic marking paint with colors per FDOT standard or thermoplastic markings.

## Demolition

- Include the removal of all items interfering with new construction as indicated in the demolition plans.
- Debris resulting from stripping and demolition operations shall be removed at frequent intervals to prevent this material from accumulating on the site.
- Removal of trees and shrubs shall include the removal of stumps and roots to the extent that no root greater than three inches in diameter remains within five feet of an underground structure or utility line or under footings or paved areas. Grubbing in open areas shall include removal of stumps and three-inch roots to two feet below finish grade elevations.
- In open areas, foundations of structures shall be removed to a minimum of three feet below finish grade elevation. Where new structures will replace existing structures, indicate extent of foundation removal on the drawings. No existing slabs will remain under fill for new structures.
- Hazardous material removal shall be conducted prior to structural removal as required by federal, state, and local requirements.
- Disposal of existing buildings and structures, trees, dismantled equipment, etc., is the responsibility of the Contractor.
- Identify cutting and patching in detail, including incidental cutting, fitting, and patching required to complete the work or to make several parts fit together properly.
- On all projects involving demolition and/or renovation, the Architect/Engineer should review with the County (for inclusion in the bid documents) the possibility of salvage of materials and equipment.
- Hazardous material such as lamps and ballasts shall be legally recycled with written provenance provided at closeout.

## Earthwork

- No excavation, drilling, exploratory work, or installation of fence posts, etc., is permitted until the Contractor has review drawings of existing utility lines.
- Control storm water drainage during construction of the project.
- Slopes shall not be greater than one vertical to six horizontal units in grassed areas.
- Steeper slopes will be considered in unique circumstances and will be reviewed and approved by the County.
- All site areas shall be designed for positive drainage with no areas of entrapment. Areas drained by piped storm water systems shall also contain a gravity outlet at least six inches lower elevation than the lowest finished floor elevation.
- Exterior finished grade shall be at least six inches below adjacent finished floor elevation around the entire building perimeter except in the immediate area of entrances and exits. Exterior grade shall then slope a minimum of 1/4" per foot away from the building for a distance of at least five feet.
- Fill under interior and exterior slabs-on-grade or pavement and fill under landscaped areas shall meet applicable ANSI/ASTM standards.
- When excavating and backfilling for the mechanical and electrical trades, the compaction of back-fill shall meet applicable ANSI/ASTM standards and the requirements of Section 553.60, F.S., the Trench Safety Act.

## Pest Control

- Termite treatment is required for every building.
- The Subcontractor for soil poisoning, must furnish a service agreement stating the work performed will be guaranteed for a period of 5 years from the date of substantial completion. In addition, the agreement must state that the structure will be inspected yearly for infestation and treatment provided as necessary. The Subcontractor shall offer an optional renewal of the service on the same terms.
- The type of chemical treatment must be specified, including the amount of application per unit area. The service agreement shall state that in the event of damage during the guarantee period, the Contractor shall make repairs to structurally damaged surfaces to a dollar value based on the size of the building.
- Chemicals and application shall conform to EPA's Federal Insecticide, Fungicide and Rodenticide Acts.

## Utility Work

- The Contractor shall make all necessary arrangements for the service, including the point of tie-in, times permitted for utility work, shutdown scheduling, traffic control and amount of lead time notification.
- The Architect/Engineer shall obtain drawings of existing utilities and shall identify services available and points of connections to services. All services shall be metered through meters furnished by the Contractor.

- Detectable plastic marking tape shall be installed underground above all buried utility lines to facilitate the location of the lines before damage to the lines can occur during excavation.
- Water main material shall be PVC.
- Provide gate valves at all new branches, fire hydrants, backflow prevention devices and meters. Discuss valve location and installation details such as valve boxes, direct burial, and ground level access to valve operator with the County. Water lines shall be disinfected according to AWWA Standard C-601. All pipes will be tested for leakage.
- Water service to all County buildings shall be equipped with a quality pressure reducing valve that is serviceable by valve pit and for such valves to carry maximum pressure setting of 65psig. PRVs shall be iron body type diaphragm valves.
- Sanitary sewers shall be PVC pipe with joints as recommended by pipe manufacturer. Sanitary manholes shall be precast concrete or cast-in-place concrete. Cover and frames shall be cast iron. Cleanouts shall be commercially manufactured wye branches.

## Paving

- All exterior ramps, stairs, landings, and walks shall have an integral non-slip finish per Florida Building Code – Accessibility requirements.
- The sidewalk and trail design must be in compliance with Florida Department of Transportation’s (FDOT) latest Standard Plans for Road and Bridge Construction, FDOT Design Manual, FDOT Standard Specifications for Road and Bridge Construction, and Florida Building Code.
- The County recommends boring as the standard procedure for underground utilities crossing streets/roads. Saw-cut finished surfaces only as a last resort. Concrete walks shall be cut and replaced from joint to joint, doveled to the remaining slab.
- Trenching of paved areas is prohibited. If directional boring is not possible, trench width shall allow the use of a full-size vibrating compactor.
- Do not install rectangular pavers adjacent to paved areas with curves. Consider stamped and colored concrete.

## Landscaping

- Imported topsoil shall be a fertile, friable, natural topsoil of loamy character obtained from a well-drained, arable site free from sticks, stones, roots, clods, and extraneous matter. Topsoil shall be a black loam, indigenous to general area in which the project is located and shall be suitable for planting and seeding. Specify a six-inch depth of topsoil for seeded areas and 12-inch depth for planting areas. Specify 18-mil weed block material for planted areas.
- Landscape Irrigation. All landscaped and sodded areas shall be irrigated with an automatic sprinkler irrigation system. The irrigation system shall be designed to

eliminate water spray on pedestrian walkways and buildings. All sprinkler lines shall be self-draining. Design the irrigation system to prevent or minimize runoff of irrigation water onto roadways, driveways, walks, etc. Specify schedule 40 PVC irrigation lines.

- All areas not otherwise landscaped shall be sodded with appropriate sod. Comply with ASPA (American Sod Producers Association) - Guideline Specifications to Sodding. Scarify subsoil to a depth of six inches where topsoils to be placed. Repeat cultivation in areas where equipment, used for hauling and spreading topsoil, has compacted subsoil. Topsoil shall be a minimum of two inches depth over area to be sodded.
- Survey existing trees to save major existing trees from damage by the new construction. Identify these trees in the landscaping plan and make provisions to keep damage and stress from occurring to the trees due to construction activity.

### Landscape Design

- From a broad perspective, the regional topography, urban form, and vegetation shall serve as points of reference, elements of continuation and, in the case of the Capitol, establish visual landmarks. The elevation changes shall serve as indicators for appropriate plant selection, from flood plain areas to uplands.
- The plant palette shall consist primarily of Live Oaks trees, Dogwoods, Redbuds, Magnolias, Azaleas and Camellias. Accent plantings shall focus on evergreen and deciduous flowering trees and shrubs which give distinction in Spring, for which the area is noted. Palm trees and other exotic plants shall be reserved for special limited plantings. The overall intent is to achieve coherence and consistency with the use of a limited palette. In so doing, the overall effect shall appear to be not only unified but set in a landscape that is part of a region and which appears to be indigenous. The designer shall seek to develop a unified landscape with surrounding areas versus an individual building zone landscape which has no relation to adjacent landscapes or larger, overall contextual landscape treatment (e.g. spatial definition, extension for overall canopy, extension of formal alignments, view corridors, etc.).
- Functional and aesthetic requirements shall consider scale, hierarchy, context, adjacencies, spatial definition, screening, buffering, shade, view corridors, and seasonal color. Landscape and plant material shall serve to complement the building and articulate main entry points and provide transitional zones between building area and larger, common open spaces and circulation areas. Plants shall also serve to buffer or screen areas such as service areas, trash dumpsters, bicycle racks and service areas. Plants shall also serve to reinforce streetscape and adjacent open spaces.
- Establish a hierarchy for landscape treatment of parking facilities. It is the intent that vehicular parking areas be both functional and aesthetically pleasing. Large canopy trees shall dominate the parking areas for shade. The trees shall have significant clear trunks for unobstructed sight visibility.
- Coordinate placement of trees around parking lots with light poles. Light poles and trees should not share a parking island or peninsula. Placement of light poles has a priority over tree locations.

- Perimeter landscape buffer areas shall be created around the perimeter of lots. The perimeter landscape strip shall be continuous except where it is pierced by access ways. The minimum width of landscape strips shall be ten (10) feet in width, and include canopy trees, groundcover, or sodded lawn areas, and continuous shrub masses to screen views of cars.
- Adequate sightlines shall be maintained between the underside of the tree canopy and the top of the shrub lines for security views inward.

## Landscape Materials

- Landscaping plant materials shall be in a schedule including plant name in botanical identification, nominal size of trunk or spread of branches, height, or other identifiable criteria. These plants shall be specified as "Florida Grade" and selected for the climatic conditions of the specific location. Coordinate the selection of all landscaping materials with County Facilities staff.
- The selection of plant material shall consider the use of plant species that are indigenous to the native plant communities of the region.
- Long term maintenance requirements shall be a consideration for plant selection. Longevity and permanence (e.g. Oak Trees) shall also be a significant factor.
- Plants shall be designed and located in a manner that is conducive to easier maintenance

## Stormwater Drainage Guidelines

- Building floor elevations shall be set to minimum standards above 100-year flood plain elevation, but in no case lower than two feet above the 100 YFP.
- Provide for no floodwater from the 25-year storm event greater than six (6) inches deep on local roads, parking lots or other non-street vehicular use areas.
- Provide catch basin or inlets of precast or cast-in-place concrete.
- Grates and frames shall be cast iron or galvanized steel.
- Drainage pipe to be concrete, corrugated metal pipe or helicoidal metal pipe (bituminous coated or aluminum).

## Concrete

### General Requirements

- Provisions shall be made for locating a dumpster receptacle and recycling containers in an accessible site with aesthetic screening provided.
- New buildings shall have at least one loading zone to accommodate frequent moving of portable equipment to and from the building and to allow maintenance vans and personnel to have ready access to the building. Where loading docks are provided, they shall be located as close as possible to freight/passenger elevators and shall be covered.

## Masonry

### General Requirements

- Tool all exposed joints slightly concave when thumbprint hard, using a joint tool larger than joint.



- Plasticizers, accelerators, retardants, water repellent agents, or other admixtures are not recommended.
- Tops of all masonry walls, exterior and interior, where applicable, shall be built tightly against the floor construction above for stability, fire and sound protection, except where provision must be made for expansion, requiring alternative means for ensuring stability, etc.
- Require composite masonry mock-ups for County approval as a standard practice. The panel shall not be removed until masonry work is completed or until removal is authorized.
- Single wythe masonry construction for exterior walls is not recommended unless approved by the County.
- All masonry units shall be properly protected at the job site to insure placing in the wall without excessive moisture content.
- All interior masonry walls exposed both sides shall be 6" thick, minimum.
- All brick shall be laid with modular coursing, three courses to 8", unless otherwise required to match existing coursing or to accentuate an architectural feature or pattern. ASTM standards shall be complied with for all face brick, Grade SW, Type FBS. In addition, manufacturer's certification will be required stating that the rating for effervescence is not more than "slightly effervesced" in accordance with ASTM.
- Cleaning should be done sufficiently early for the walls to dry thoroughly; at least four weeks prior to application of silicone or other recommended waterproofing.
- Specify cleaning agents of detergent or solvent. Acid solution is not recommended.

## Metals

### General Requirements

- All structural steel work shall comply with AISC "Specifications for the Design, Fabrication and Erection of Structural Steel for Buildings" and applicable ASTM Standards.
- All exterior ferrous metals shall be hot-dipped galvanized including all shelf angles and other metal used in cavity walls, whether it is exposed to view.
- All iron and steel items must be shop primed and have additional coats applied at the job site as required to prevent rusting.
- All exterior ferrous metals exposed to view shall be primed and painted with a paint coating designed for compatibility with the galvanized surface on which it is applied.
- All interior ferrous metal shall be painted with three mils of paint on all surfaces.
- All metal components shall conform to applicable ASTM requirements, including gratings, castings, supports for ceiling hung equipment and framed partitions, construction inserts and fastening devices, expansion joint inserts and covers, stair nosing and access doors for both ceiling and wall applications, vertical ladder for elevator pit; welded steel ladder (to meet OSHA,) elevator pit sump gratings; corner guard angles; steel angles, channels and clips; pipe sleeves for

mechanical and electrical trades; trench drain gratings and frames; galvanized steel corner guards and, miscellaneous structural shapes.

- Handrails shall comply with all applicable codes.
- Tree grates shall be of dimensions as required with concentric patterns having gray iron frame sections and gray iron grate bolted to the frame.

## Wood and Plastics

### General Requirements

- Provide pressure treated lumber for all lumber in contact with concrete, masonry, or steel.
- If plastic laminate is used, a backing sheet of manufacturer's recommendation must be specified. This material shall meet flame spread-rating requirements of NFPA 101 for interior finish consistent with the occupancy classification.
- Wood handrails shall return to walls and/or newel-posts.
- All lavatory counters shall be of solid surface material (example: DuPont Corian), have a seamless surface with back splashes at least four inches high.

## Thermal and Moisture Protection

### General Requirements

- Water-proofing products (sheet butyl, PVC, EPDM, CPE, CSPE, neoprene, Hypalon, or composite laminated membrane) shall be designed to function as principal moisture stop in arresting water predominantly in a horizontal application; adhesive bonded, self-adhered, loose laid, or mechanically secured installation.
- Slabs on grade shall be designed and installed so as to prevent damage to membranes during construction. At special areas and where waterproofing is considered necessary for slab on grade, a double slab system is preferred in order to reduce chances of a punctured membrane. A product equal to "Bituthane" by W. R. Grace should be considered under the wear slab.
- For a basement waterproofing condition, a water bar is essential at walls and columns.
- If a Radon Barrier is required, special consideration shall be given to design.
- Provide a through-wall damp-proofing membrane to prevent moisture in the soil from extending up the wall by capillary action. Material can be as light as 2 oz. copper-backed sisal paper if properly lapped and sealed at joints.
- Basement walls shall be damp-proofed or waterproofed on the soil side. The type of material to be used depends upon the condition; a sprayed or brushed-on coat of bituminous coating might be adequate for dampness but sheet membrane waterproofing or "Bentonite" or equal should be considered where hydro static pressure is expected.
- Special consideration shall be given to preventing leakage in shower and drying room areas, especially on elevated floors.
- A depressed floor shall be provided for toilet areas where ceramic tile is used to allow space for the waterproofing pan and slope to drain.

- In waterproofed floor areas, a 24-hour water test is required prior to placement of the finish flooring. If a leak occurs, another test is required after repairs are made.
- Water repellent materials shall be a clear elastomeric water repellent.
- Provide a method used to continue a seal formed by a vapor and air barrier for each building enclosure construction, and to seal gaps between adjacent materials forming wall and roof openings.
- Fire stop material shall be used to close openings and continue a fire resistance rating uninterrupted.
- All gutters and downspouts, hangers, straps, and shoes shall be completely detailed and/or described. Gutters and downspouts shall be held 1" from the building wall to allow air to circulate between gutter/downspout and wall surface.
- Specify that sealants, caulking and seals shall be done by experienced mechanics. Provide the highest quality of sealants for each individual application.
- Evaluate life-cycle costs for sealant products. In addition to caulking for water tightness, caulking shall be specified for finished appearance, i.e., at cracks between the juncture of different materials or of horizontal with vertical surfaces. Caulking is not to be used as permanent construction. Caulking shall be specified for use only as a supplement to properly designed and detailed joints.

## Roofing

- Sheet metal flashing and trim. Shall be provided in accordance with the Architectural Sheet Metal Manual by the Sheet Metal and Air Conditioning Contractors National Association (SMACNA).
- All roofing design and details shall comply with the National Roofing Contractors Association (NRCA) Roofing and Waterproofing Manual, current edition.
- Existing roofs shall be tested using infrared equipment prior to demolition to determine moisture content in the layers below the roofing membrane to establish extent of demolition of these elements.
- Post construction water testing shall be conducted on all new roofs as indicated in the County's roof testing requirements.
- The County prefers clerestory structures in lieu of skylights.
- Provide overflow scuppers in parapet walls two to four inches above roof level.
- Where gravel stops are used over exterior surfaces, provide high gravel stops, to prevent water from spilling over with resulting stain effect.
- Roof slopes shall be maximized, but in no case less than slopes as prescribed by the National Roofing Contractors Association (NRCA) Roofing and Waterproofing Manual. The slope of the roof can be obtained either through the structural design or tapered insulation. The design and workmanship of the finished roof shall be such that no water shall pond on the roof surface more than 24 hours after a rainfall.

- An interior means of gaining access to the roof shall be provided with locking capability.
- The Architect/Engineer shall specify a minimum of three manufacturers of roofing systems and shall obtain notarized letters from each factory technical representative that the type of roofing system specified will perform in this locality and that all materials delivered to the job site and used by the contractor complies with the specifications. Minimum warranty shall be 20 years unlimited with no dollar limit.
- Roof drainage systems shall be unobstructed, properly connected to storm drains and designed and installed as per the Florida Building Code.
- If pre-stressed concrete structural members are used to support flat roofs or roofs with minimum pitch (with or without a light-weight concrete topping poured on the structural members), an expansion joint shall be provided at the ends of each pre-stressed section where the structural members butt together to allow for proper expansion.
- The roof insulation shall be applied in two layers with no bonding applied between the two layers. Regardless of the thickness required to obtain required pitch or "R" rating, the thickness shall be enough to prevent expansion and contraction of the pre-stressed members. The bottom layer of insulation shall be bonded to the felt layer above. Care shall be taken to avoid coincident placement of joints.
- On all built-up or membrane roofs, roof walkways shall be provided from roof access point(s) to and around all roof installed mechanical or electrical equipment.
- Do not provide rooftop exposed ductwork. Rooftop mounting of HVAC equipment shall avoided where possible.
- Parapet walls and caps (or coping) shall have through the wall flashing. If limestone caps are used, they shall have a lead "T" shaped cap embedded in caulking between each piece of stone cap. Mortar shall not serve this purpose.
- Warranties from roofing manufacturers shall include coverage for installation as well as materials. In the event of roofing material failure, the roofing manufacturer shall warrant all costs of roofing repairs, including labor. Warranty shall be in effect for as long as the material warranty is in effect.
- Roof installations must meet current wind load design standards.
- All new roofs and re roofing projects shall include a complete gutter systems with downspouts

### Exterior Closure Assemblies

- Do not use exterior wall assemblies that have not been tested for a 20-year guaranteed lifespan. Exterior Insulated Finish Systems shall not be used.
- Do not rely on sealants alone to prevent water infiltration.
- Ensure that the entire building exterior moisture barrier systems have continuity and form a continuous, uninterrupted barrier to water infiltration.
- Do not use galvanized metal for flashing.

## Doors and Windows

### Doors and Frames

- All exterior doors shall be insulated metal doors with adequate weather stripping and threshold utilized to conserve energy. If glass is used, the glass shall be thermal/safety glass, and non-reflective.
- Exterior doors shall be of "monumental" quality, minimum width of each leaf 3'-0" and minimum height of 7'-0". In renovation projects, a different height may be used, if appropriate.
- Interior doors shall be 3'-0" wide minimum x 7'-0" high each leaf, except that in renovation projects the door height shall match existing. Do not mix door heights in adjacent areas. All doors shall be solid core wood stave.
- All doorways shall be numbered. Do not place number on door, but to the open side with raised numbering at a height of five feet.
- View panels in any fire door shall conform to Florida Fire Prevention Code specifications.
- Install doorstops on all doors.
- All hollow metal door frames shall be made of min. 16-gauge metal. Provide reinforcing of frames for hardware. A light angle is desirable. Where two doors swing from the same mullion the metal should be of heavier material and reinforced.
- If large equipment occurs in a room, provide doors of adequate width to provide clearance for moving the items in or out. If size is questionable, use larger size opening.
- All corridor doors and doors to closets shall be 1-3/4" solid core to meet requirements of NFPA 80 and 101, and able to use standard locksets. Where cutouts for closers are required, the head rail should be not less than 6 inches. If hardwood edges are desired, they should be completely specified with the thickness given. Wood doors shall meet the Standards of The National Woodwork Manufacturers Association.
- Wood door quality shall be clearly specified as well as manufacturer's name noted.
- Plastic faced wood doors shall conform to NEMA LD3 Adhesives for both exterior and interior shall conform to ANSI/NWMA-IS.1.
- Louvred exterior doors are not to be used in rural and un-maned locations

### Door Hardware

- Include a completely itemized hardware schedule in the specification. The hardware schedule shall include a complete list of items proposed as standard, together with manufacturers' names and with the names of manufacturers whose products are proposed as equals.
- Specify one manufacturer as standard and, whenever possible, at least two other manufacturers whose products are proven equal.
- The hardware supplier shall furnish to the door manufacturer templates or the actual hardware.

- Hardware added to existing buildings will be of the same manufacturer as the existing hardware, unless specified otherwise, and shall follow the Florida Building Code - Accessibility.
- Provide latch guards at secure exterior doors.
- Review with the County regarding electronic building card access and control systems.

### Keys and Keying

- All door locks shall be purchased with Best removable core cylinders “less cores.” The County will accept no substitutes. All final cores and keys will be supplied and installed by the County, to maintain consistency of County master keying systems and to maintain control over final keys. The Contractor must coordinate installation of cores with the County and the County’s Locksmith.
- Cores for all exterior doors and certain high security interior doors shall be keyed using a non-duplicable Best patent keyway.
- The Contractor will supply and install temporary construction cores and provide construction personnel and the County with keys during construction.
- All keyed locks shall be grand master reserved and subject to the Zone Master as assigned to the facility by Leon County Facilities Management.

### Electronic Card Access

- Review each project with the County regarding electronic building card access and control systems.
- Where the County elects to include an Electronic Card Access system, provide a system compatible with existing County security and monitoring systems.
- Card readers and keypads shall be installed 40” to bottom of box per LC MIS.

### Window Guidelines

- Do not locate glass in areas that are inaccessible. Exterior windows shall be accessible for washing either by manually operable sash, the use of a swinging scaffold or the use of safety gear that snaps onto the window frame. Each window shall be properly equipped with anchors to support safety gear.
- Consideration shall be given to the use of double panes (thermopane) with outer shield of solar glass, especially if windows area exceeds 3% of wall area.
- Provide guardrails at all full height glass panels in accordance with applicable codes.
- Confirm that any hurricane shelter requirements have been considered in the design of windows and selection of window materials.
- Types of glass and location shall be indicated on the drawings or in the specifications.
- Use obscure glass in toilet and bathroom windows.

- All window glass shall be replaceable from inside the building wherever feasible.
- Specify safety glass in all hazardous locations in compliance with the Florida Building Code.

## Finishes

### General Guidelines

- The Architect/Engineer shall coordinate all color and material selections with the County. Color schedules will be required for review with the submittal of 50% construction documents. Schedules and samples shall be provided for interior finishes, such as paint, vinyl, baseboards, carpet, tile, bathroom partitions, and the like as well as exterior finishes, such as paint, roof shingles, glazing, and so on. Colors shall be presented in the form of a non-returnable "color-board," which demonstrates all color selections in the form of an overall project color palette. In case of special concrete finishes or stucco work, a sample at least 2'- 0" square shall be submitted.
- As a minimum, use a latex-based semi-gloss paint on all wall surfaces to be painted to facilitate cleaning. Use water-based epoxy paint behind and beneath water coolers, trash receptacles, adjacent to elevators, in vending rooms and in all restrooms.
- All plastic laminate surfaces shall have a matte finish.
- Blown-on acoustical ceilings and walls are not acceptable.

### Carpet

- Carpet grain direction, seaming, and scribing shall be carefully addressed in drawings and specifications.
- All carpet, unless otherwise specified, shall run in the same direction. Lay with a minimum number of seams and carpet sections. All carpet is to be smoothly laid with no bubbles, ridges, etc.
- Where roll carpet is used, no seams shall occur at doorways and entries perpendicular to doors and entries. Seaming occurring at doorways parallel to doors shall be centered directly under doors.
- When seams occur at corridors, change of directions shall follow wall line parallel to carpet direction.
- Cross-joints, which are necessary due to length of rolls, shall be placed in the cutting, to avoid occurrence at conspicuous locations, near doors, or at pivot points.
- Where needed, raw carpet edges at doorways and the like shall be finished with a high-quality metal strip or molding.
- Do not specify carpet in stairways.
- Specify 5% surplus carpet to be retained for the County replacement stock.

## Carpet Quality Assurance

- Fire Performance Characteristics: Provide carpet that meets or exceeds code requirements.
- Appearance Retention Rating (ARR): Test Method: Carpet and Rug Institute (CRI) test TM101 graded in accordance with ASTM D-5252(hexapod). Rating:4.0 or higher.
- Colorfastness to Light: Test Method: AATCC-16, option E. Rating: 4 minima, 4.5 for heavy light exposure locations, after 40 AATCC fading units using AATCC gray scale for color change.
- Soiling Resistance: Test Method: AATCC 189 Rating: An average of 3 fluorine analyses of a single composite sample to be a minimum of 500 ppm fluorine by weight when new and 400 ppm fluorine by weight after 2 AATCC 171 (HWE) cleanings.
- Stain Resistance: Test Method: Red Dye 40 Test. Rating: 8 or better.
- Durability Characteristics: Tuft Bind / Edge Ravel: Test Method: ASTM D-1335. Rating: 10 lbs. Of force or higher, wet. Delamination Strength of Secondary Backing: Test Method: ASTM D-3936. Rating: 2.5 lbs. of force per inch width. Dimensional Stability of Modular Carpet: Test Method: Physical measurement. Rating: within 1/32” of specifications.
- The manufacturer shall supply unrestricted, full replacement non-prorated warranties guaranteeing wear no more than 10% yarn loss by weight for a minimum of 15 years of carpet under normal use, no edge ravel in normal use for a minimum of 15 years of normal carpet use, no zippering for a minimum of 15 years of normal carpet use and no delamination of primary and secondary backings for a minimum of 15 years of normal carpet use.

## Carpeting Products

- Based on appropriateness of use, carpet selections shall be made from the following:
- Broadloom Carpet – 12’ roll goods. Tufted level or multi-level loop pile.  
Dye Method: 100% yarn dyed, solution dyed, or a combination of yarn dyed, and solution dyed. Pile Weight: 26 oz per square yard or higher measured according to ASTM D-5848. Stitches: 8.3 per inch minimum measured according to ASTM D-5793. Pile Height: 0.145” minimum measured according to ASTM D-6859. Primary Backing: Woven polypropylene or equal. Secondary Backing: Woven polypropylene or equal.
- Hard-backed Carpet – Same as above except 6’ roll goods, solid backing impervious to moisture; primary backing: reinforced synthetic; secondary backing: fiberglass reinforced thermoplastic composite; pile weight: 22 oz per square yard or higher measured according to ASTM D-5848; and stitches: 10.0 per inch minimum measured according to ASTM D-5793.
- Modular Carpet – same as hard backed carpet except supplied as individual solid backed carpet squares. Install with releasable adhesive. Recommended for general use and where additional cleanability, acoustical



dampening and durability is desired. Modular carpet is recommended where frequent carpet replacement is anticipated, where access to the substrate is necessary and where replacement of roll goods is impractical due to obstructions in the space.

- Solution Dyed Carpet (Lumena) – made with carpet yarn that has color throughout the yarn and therefore has superior color retention and resistance to fading. Solution Dyed Carpet may be supplied as Broadloom, Hard-Backed or Modular. Solution dyed carpet is recommended for general use and use in areas with high sunlight exposure and/or potential exposure to bleaching agents, such as areas near toilets or janitor’s closets where bleach is used in cleaning.
- Carpet Adhesive: Provide highest quality adhesive recommended by the carpet manufacturer for intended use condition. No substitutions. All adhesive used for modular carpet tile shall be a releasable adhesive.
- Carpet products shall be applied to areas within projects according to the following recommendations:
  - Very High Traffic Zones – Immediately inside entrance doorways, elevator doors, and other places where traffic is very highly concentrated. Use tile, walk-off mats, or similar materials in the immediate vicinity of the doorway, elevator entrance or other high traffic zone. As traffic concentration begins to be more spread out, transition to carpet, using the recommendations below for High Traffic zones.
  - High Traffic Zones – Modular Carpet is recommended for High Traffic Zones where frequent carpet replacement is likely. Transition to Hard Backed Carpet as traffic becomes less concentrated, and frequent carpet replacement becomes less likely. These zones must be designed carefully and with respect to the challenges of each project, but, in general, the designer should consider Hard Backed Carpet in corridors, lobbies, atriums, aisles, walkway areas within open office areas and similar spaces. Consider the transition of this thicker carpet to adjoining areas using Broadloom Carpet.
  - Areas with High Sunlight Exposure or Exposure to Bleaching Chemicals – Use Solution Dyed Carpet for superior color retention and resistance to fading. Provide this carpet as a Broadloom, Hard Backed or Modular design, depending on the traffic characteristics of the space, as outlined above. Examples of such areas are Atrium spaces located inside large areas of South- facing glass, spaces adjacent to any spaces using chemicals with bleaching properties, and carpeted areas adjacent to custodial closets and toilets.
  - Other areas, including offices and other spaces, can be carpeted with Broadloom carpet, at the discretion of the designer and the County. Careful consideration should be given to the use, traffic load, and sunlight exposure of each area in choosing the most effective carpet for that area.

## General Carpet Installation Guidelines

- As job progresses, surplus adhesive squeezed out between joints shall be removed. Any stains remaining shall be removed by approved methods.

- Upon completion of work, all base and edging shall be cleaned, all foreign materials removed by approved methods.
- Installation of carpeting and related items shall be done by a competent contractor normally engaged in this trade with materials and methods complying with the specifications and drawings, and in such a manner as to insure a workmanlike job.
- Moisture tests of substrates are required prior to the installation of carpet and vinyl tile in new structures. A satisfactory reading, conforming to the manufacturer's requirements, shall be obtained before installation is permitted.
- Carpet shall not be installed prior to drywall installation.
- Floors shall be free of all wax, grease, paint, oil, or any other substance that would create adherence problems. Cracks, expansion joints, etc. are to be filled with a top-quality patching compound and finished smoothly.
- Cut edges on all roll carpet are to be treated with a seam sealer at the edge of the carpet at the base of the pile and primary backing. On all carpets, excess sealer is to be removed in accordance with the manufacturer's recommendations.
- To insure an almost 100% contact with the adhesive, the carpet is to be pressed with a roller or push broom per the manufacturer's standard procedures. Note: Carpet with an attached cushion is not to be treated with a floor-covering roller exceeding 30 pounds.

### Resilient Floor Tile and Related Products

- Immediately upon completion of the tile installation, apply a high-quality floor sealer and the minimum number of coats of floor finish recommended by the manufacturer to prevent damage to the floor during construction. Re-coat prior to acceptance of the facility by the County.
- Specify 5% surplus resilient tile and base to be retained for the County replacement stock.
- All surfaces on which resilient flooring and edging are to be installed shall be cleaned free of grease, dirt, paint, and hardeners. Holes, cracks, and other depressions in the existing floor slabs shall be filled or patched and brought to a true plane with a non-shrinking grout.
- Floor tile shall be laid with close, even joints, to a smooth, even surface, and square with the corridor axis.
- Floor tile shall be laid with the grain direction alternating in a checkerboard pattern.
- Floor tile at borders on opposite sides of the space shall be equal, and shall be laid, cut, fitted, and scribed to walls, columns, door frames, and the like after laying of the field tile.
- Use molded inside and outside corners. No scribed corners are permitted.
- Base and molded corners shall be firmly cemented to walls and other vertical surfaces with tight joints. Base throughout its entire length shall have its top

and bottom edges in firm contact with the floor and walls. Base shall be scribed accurately to molded corners and to doorframes.

- Adhesives for flooring and accessories shall be of the types specifically recommended by the resilient material manufacturers for the installation conditions involved. For the installation of floor tile and edge strips, waterproof adhesive only shall be used.
- All resilient tile and resilient base shall be of the same millrun to maintain consistency.
- All resilient edging strips shall be vinyl with factory formed feathered edge.

### Ceramic Tile

- The current edition of "The Handbook for Ceramic Tile Installation," published by the Tile Council of America, shall be used as a reference guide for selecting design details and specification wording.
- Ceramic tile is desirable for floors and walls or wainscots in toilets as well as in other wet areas where frequent cleaning is necessary. Toilet floors shall have dark sealed grout.
- Where ceramic tile is used on shower room floors and walls, specify parging or painting the back-up wall material, flashing at base and waterproof pans under floor tile, detailed to prevent water penetration. Ceramic tile on a masonry wall is insufficient to prevent water from permeating a shower room wall.
- Specify 5% surplus tile to be retained for the County replacement stock.

### Acoustical Ceiling Tile

- Use extreme care in choosing the correct acoustic units. Do not specify exotic patterns, etc. Ensure that only standard patterns have been specified that will be available for many years in the future.
- 2'x2' ceiling tiles are standard. Provide a deduct for 2'x4' tiles.
- Specify that the Contractor cannot accept discontinued acoustic units.
- Specify acoustical ceilings, not only by noise reduction coefficient, but also by tile thickness.
- Specify mechanical suspension of acoustical ceilings. Adhesive attachment is not permitted.
- Where exposed grid systems are specified, a reflected ceiling plan is required on the drawings.
- Specify construction tolerances regarding plumbness, dimensions and locations, particularly where exposed masonry and concrete is used.
- Acoustical ceiling tiles shall not be installed until the building is conditioned. Sagging tiles shall be replaced.
- Specify 5% surplus ceiling to be retained for the County replacement stock.

## Painting

- Specify the total thickness of paint by "dry mil" or "wet mil" thickness (according to which is recommended by the paint manufacturer), and verify the thickness on the job by use of gages.
- Paints with the highest proportion of titanium dioxide should be used for dirt shedding properties.
- Require metal doorframes in masonry walls to be back painted prior to installation.
- Specify paint on steel and iron items based on mil thickness. Items exposed to the weather shall have a minimum of six mils total dry film measurement. Interior steel and iron shall have a minimum of four mils dry film measurement.
- Use a clear silicone waterproofing or approved alternative on the exterior of all brick buildings including stone. 3% silicone is considered adequate; for limestone a 5% silicone is desirable.
- Clear silicone waterproofing shall contain a minimum of 3-5% silicone resin solids in a hydrocarbon solvent.
- Where an interior paint is used on masonry or concrete surfaces, no silicone waterproofing is desired.
- Use latex based paint for interior applications and an oil or epoxy-based paint for exterior.

## Specialties

### Toilet Accessories

- Fixtures and partitions shall be wall or ceiling hung to keep floors clear for cleaning. Fastening is to be by means of toggle bolts and through bolts into studding, stringers, joists, concrete, or solid masonry. Attachment to wall finish only is not permitted.
- All items are to be securely installed. In drywall partitions, use solid wood backing. All toilet partitions shall be solid plastic.
- Provide coat hooks on the inside of each stall door.
- Soap dispensers, toilet tissue and paper towel dispensers shall be as specified by Leon County Facilities Management
- Provide sensor operated hand dryers where possible.
- Provide wall mounted, semi-recessed stainless-steel waste receptacles.
- Provide stainless steel sanitary napkin receptacles in all female toilet stalls.
- Provide a stainless-steel utility shelf for extra tissue and paper towels in each restroom.
- Mirrors are to be provided for all restrooms. Do not place mirrors in open view of the entranceway.

## Signage

- The facility street number shall be displayed at all times on the building and shall be six inches in height. Additionally, install three inch high numbers on each electric meter. Failure to maintain will delay the final inspection.
- Provide marking, signage and other identification for all mechanical and electrical equipment and piping.
- Provide clear marking in accordance with Florida Building and Florida Fire Prevention codes for all fire rated wall assemblies.
- Provide a sign at each floor level landing in accordance with applicable Florida Building Codes. The sign text and location shall comply with all applicable Codes and Standards.
- Provide directional signs for direction of the public through corridors to destination.
- Provide occupancy limit signs as required by all applicable Florida Building Codes and Standards.
- Submit to the County for approval details relative to materials, dimensions of individual components, profiles, and finishes for each type of sign required. Provide shop drawings for fabrication and erection of signs. Include plans, elevations, and large-scale sections of

## Room Signage

- Designate room numbering schemes with approval by the County to assist way finding and facilitate identification of spaces for inventory and other purposes.
- Provide individual routed cast acrylic signs for each space clearly identifying room number and name.

## Building Plaque

- When requested by the County, the construction contract shall contain an adequate allowance for the installation by the contractor of a cast metal building plaque for all new facilities. The size and location of the plaque in the building, and the information it contains shall be as determined by the County

## Fire Extinguishers

- All fire extinguishers shall be of the size, type, and location distribution as per NFPA 10, current edition.
- Fire extinguisher cabinets – Use only UL approved pull open, non-locking cabinets, with a flat, shelf bottom. All cabinets shall be fully or partially recessed. Do not use ‘bubble front’ units.
- Use non-water-based fire extinguishing agents in computer rooms and laboratories where sensitive equipment exists. Consult with Leon County Facilities Management for approved extinguishing media.

- Install fire alarm panels at the front door.

### Louvers

- All wall louvers shall be extruded aluminum, storm proof, and include bird screens.
- All louver perimeters shall be sealed to provide full perimeter integrity.
- Meet hurricane requirements where required.

### Wall and Corner Guards

- Provide wall and corner guards, in conjunction with door kick plates, where necessary to protect walls and other surfaces from damage and reduce maintenance.
- Where wall and corner guards are used, provide high impact vinyl or stainless steel with approval of the County.
- Provide 3/16" or a heavier gauge PVC to prevent warping

## Equipment

### Trash Handling Equipment

- Provide a careful plan for the sanitary collection, storage, and removal of trash from every facility by means appropriate to the project.
- Install trash chutes and trash compactors in new facilities where approved by the County.
- Establish on site recycling areas accessible to staff members assigned to the collection and pickup of recyclable materials. (i.e., immediately off-loading docks or accessible by paved sloping walkways, not stairs.)
- Buildings three or more stories high shall be designed with a trash receiving room large enough to place a 10-cu. yd. (8' wide X 7' deep X 8' high) steel trash collection box directly below a vertical chute. (A roll-up door is suggested, not less than 10' X 10'.)

### Loading Dock Equipment

- Provide loading docks in new facilities where the use demands frequent deliveries or shipments.
- All loading docks shall be equipped with leveling platforms and be covered to accommodate deliveries in inclement weather.

## Furnishings

### General Guidelines

- Trash receptacles shall be located outside each elevator door, each building entry and in all hallways and lobbies where appropriate. Receptacles shall have hinged doors or be removable.
- Building directories shall be provided in all main lobbies.

- All shelving shall be adjustable except when a specific installation is impractical.
- Bulletin boards and display cases shall be provided as designated by the County.
- Entrance floor mats shall be recessed flush with finished floor and be provided inside and outside of all building entrances. Where possible, recessed, and replaceable walk off mats shall have a 12-foot run length inside of all entrance doors. Exterior mats shall be a minimum of 4x6 for a single door, and 6x8 for a double door. Exterior mats shall be of the type to scrape and remove heavy dirt and soil.
- In rooms designed for frequently moved furniture or equipment provide a chair rail or guard around room perimeter to protect wall finishes.

## Elevators and Chair Lifts

### General Guidelines

- Elevators and support spaces shall be designed and constructed in strict accordance with all applicable Florida Building Codes and Standards.
- Require installation by an approved contractor regularly engaged in manufacturing elevator equipment of the type required for this project with not less than ten (10) years of satisfactory experience.
- The approved elevator Installation Technicians must be certified with a “Certificate of Competency” from the State of Florida. During the Contractor’s Warranty period, the Contractor shall be responsible for providing additional maintenance, repairs, service, call-backs, and other work on a 24 hour, 7 days per week basis as part of the installation or modernization contract. Response time for any problem calls must be within one (1) hour after notification of the problem.
- Conductors to elevator equipment shall be copper with a full-size grounding conductor.
- 70 620.22(A) A separate branch circuit shall supply the car lights, receptacle, aux lighting power and ventilation for each car. The overcurrent device protecting the branch circuit shall be located in the elevator machine room.
- 70 620.23(A) A separate branch circuit shall supply the machine room lighting and receptacles.
- 70 620.23(B) The machine room light switch shall be located at the point of entry.
- 70 620.23(C) At least one receptacle shall be provided in each machine room.
- 70 620.24(A) A separate branch circuit shall supply the hoistway pit lighting and receptacle.
- 70 620.24(B) The light switch shall be located as to be readily accessible from the pit access door.
- 70 620.24(C) At least one receptacle shall be provided in the hoistway pit.
- 70 620.53 Elevators shall have a single means for disconnecting all car light, receptacles and ventilation for that car. The disconnecting means shall be an enclose externally operated fused motor circuit switch or circuit breaker that

is lockable open in accordance with 110.25 and shall be located in the machine room for that elevator car.

- 70 620.85 Each receptacle installed in pits, hoistways, on car tops shall be GFCI. Receptacles installed in each machinery rooms shall be GFCI. A single receptacle supplying a permanently installed sump pump shall not require GFCI.
- 72 23.8.6.2.2 Notification device (Incl visible) shall not be required in elevator cars.
- Confirm requirements of ASME A17.1 are met requiring 5 FC at pit floor with externally guarded.

### Elevator Pit & Hoistways

- The elevator pit area, which includes the floor and walls up to the lowest landing threshold area, must be water sealed and painted with two (2) coats of high gloss acrylic latex floor enamel.
- Where needed, grating shall be provided in shafts to permit safe lubrication of sheaves and equipment.
- No foreign piping, ductwork or conduit shall pass through hoistway.

### Elevator Mechanical Room

- The elevator machine room shall be no larger than necessary to house and repair machinery. The elevator machine room walls and ceiling must be primed and completely painted with two (2) coats of semi-gloss acrylic latex paint. The machine room floors shall be smooth and level. The elevator machine room floors must be painted with two (2) coats of oil-based light gray color gloss floor and deck enamel.
- No foreign piping, ductwork or conduit shall pass through the machine room. With the use of Microprocessor based elevator control system, the elevator machine room must be environmentally controlled.
- Elevator machine rooms shall not be located adjacent to noise sensitive spaces without thorough consideration and design to mitigate noise transmission to these spaces.

### Elevator Maintenance and Repair

- As part of the Closeout Documents, the Elevator Contractor shall provide the following:
  - Serial number specific operation, adjustment & maintenance data; tools or computer devices, for each elevator (or for each multi-car group elevator system) elevator electrical controller and door operator control.
- Four (4) copies of typewritten elevator serial number specific installation, adjustment and troubleshooting instructions, to be used in maintaining and repairing all new, upgraded, or renovated elevators or group elevator systems.
- Four (4) copies of the elevator serial number specific, as built, electrical wiring diagrams, designed with point to point wiring or circuit connections. Further,



furnish a complete set black on white drawings to be used for reproduction of wiring diagrams, if needed in the future. Additionally, provide one (1) complete set of the same wiring diagrams, laminated with heavy gauge clear plastic, and designed to be hung on sturdy wall bracket(s) in the elevator machine room(s). Drawings shall be designed to be easily removed from the rack for use by the elevator technicians.

- Four (4) copies of all elevator serial number specific computer or handheld adjustment device passwords, legends, reference codes, key words, operational descriptions and related information so that a competent elevator technician can access the elevator electrical controller system(s), make adjustments to the equipment settings, determine the malfunction codes, troubleshoot the electrical system or verify correct operation of the elevator electrical controller or door operator equipment.
- Four (4) copies of an elevator serial number specific replacement parts list for each elevator or group of elevators, located in a new building, or that which is renovated or in an existing building. Elevator Contractor shall have the right to furnish either “on board” mounted computers or hand-held diagnostic devices, or similar portable computer or handheld devices that can be disconnected from the elevator electrical controller and door operator controller systems. Either design is acceptable so long as the required maintenance and adjustment information, diagnostic functions, equipment operation, equipment performance and troubleshooting activities can be performed without unnecessary delays, and the same performance results can be anticipated. Regardless of the type of computer or diagnostic equipment provided under the contract, the Elevator Contractor must provide the County with one (1) complete set of computer or handheld technical equipment devices that will operate each and every elevator covered by the new elevator or elevator upgrade contract.
- A complete set of current, as built and installed, microprocessor software for each elevator covered by the contract.
- A notarized letter with the Contractor’s bid that states that, if the Elevator Contractor receives the contract to perform the elevator work, the Elevator Contractor shall provide all of the required installation and adjustment information, computer devices or service tools, data, instructions, diagrams, parts lists and related information at the time the project is completed. All required information, data, diagrams, instructions, and related materials shall be provided in heavy duty, oversize type, three (3) ring binders, properly identified with the project name, locations, elevator serial numbers, building elevator numbers and related information.

### **Elevator Replacement Parts**

- All of the major parts utilized in new or up-graded elevators must be manufactured in North America, and the elevator manufacturer must have a documented quality assurance program.
- Only new parts or components shall be accepted. The installer shall not use rebuilt, used, or reconditioned equipment or parts on any new elevators or up-graded elevators.

- The Elevator Contractor, and Elevator Manufacturer, if not the same company, must provide a notarized letter at the time the elevator work project is bid stating that all necessary replacement parts, supplies and related equipment, necessary to maintain, repair and service the elevator equipment will be promptly sold, without delays, directly to the County, or to the Elevator Contractor who maintains the elevator equipment on behalf of the County without the necessity of the replacement parts being initially purchased by the County. The letter must be signed by an executive officer of the Elevator Contractor.

### Hydraulic Elevators

- Elevators not on emergency generator system must have a battery lowering system.
- The pit channels must receive a rust inhibitive primer and two (2) finish coats of paint before installation.

### Traction Elevators

- All elevator driving machines and elevator controller equipment must be installed in a machinery room separate from the hoist way area.
- Provide access door leading to metal gratings that shall be provided in shafts, where required by code, to permit access for lubrication of sheaves and equipment.

### Elevator Cabs

- Elevator cabs for new or up-graded elevators must have hinged, swing type front return panels to contain all the operating devices, stainless steel vandal resistant buttons, indicators, standard size certificate holder, emergency phone, handicapped markings and other devices.
- All mounting must be from the rear to provide neat and vandal resistant panel.
- Front return panels must have heavy hinges, and vandal resistant locking devices.
- Independent service, etc. shall be in a separate cabinet with a locked, hinged door.
- Cab wall and ceiling finishes shall be stainless steel. Floors shall be ceramic tile or resilient floor tile. Refer to Division 9 - Finishes of this guide for further requirements.

### Freight Elevators

- Freight elevators shall be near docks and service area. They shall go to each floor and be of sufficient size to accommodate large equipment.
- In the event a freight elevator is installed in a corrosive environment or installed in conditions that require sanitary environment, the equipment shall be fabricated from extremely corrosion resistant and/or materials that are easily sanitized.

- Provide highly accurate electronic load weighting device, overload alarm and signal light. Alarm and signal light shall function if load exceeds design capacity. Elevator shall not function if overloaded conditions exist.

## Chairlifts

- Any chairlift placed outside of a building must be manufactured to withstand wet conditions and be placed in surroundings to protected from weather.

## Mechanical Systems

### General Mechanical Guidelines

- It shall be the responsibility of the Architect/Engineer to investigate and determine the actual location of all underground utilities or obstructions at the building site before beginning design work.
- The specifications shall provide requirements for the orientation and training of County personnel on all installed equipment and systems.
- Where required by the County, prepare an energy life cycle cost analysis. Use industry standard cost analysis software.
- All HVAC equipment shall be three phase where available.
- Refrigerant line and thermostat cables shall be installed in conduit underground or underslab rising to the appropriate condensing unit. Surface mounted or exposed refrigerant piping is prohibited.
- Provide separation of mechanical equipment and other noisy areas from office areas, conference rooms and other noise sensitive spaces.
- Provide a chart showing the pressure relationship of all rooms.
- Airflow under doors are calculated by the equation  $Q(\text{cfm}) = 2610 * A(\text{ft}^2) * P^{0.5}(\text{inwc})$
- Provide a 1" door uncut for air transfer of 65CFM and less and 1 1/2" for 100CFM. Do not exceed 100CFM for under door air transfer.
- Confirm undercuts are shown on the architect's door schedule.
- Care shall be taken in the placement of all outdoor air inlets to ensure that odors and other pollutants (automobile exhaust, generator exhaust, fume hood exhaust, etc.) do not enter the building.
- Mechanical rooms must have adequate openings to facilitate the removal and replacement of major pieces of equipment. Provide a minimum of double 3'-0" doors which outward swing, with active/inactive leaf.
- There must be adequate space in mechanical rooms to provide ample access space around all equipment for routine maintenance items and procedures, such as filter replacement, lubrication, and so on.
- Access to electrical rooms, mechanical rooms, communications closets, elevator machine rooms, fan rooms, pump rooms, etc., shall not be through other rooms. It is preferred that access to these spaces be achieved from a main corridor and/or exterior space. Access shall not be by ladders. Where possible, penthouse rooms shall have elevator access.
- Mechanical Rooms and similar spaces are not to contain storage areas.
- All power disconnects to equipment shall be so located as to be easily accessed.

- All piping shall be color coded and labeled as to its use according to ANSI A13.1. Pipes shall be marked adjacent to all valves and flanges, adjacent to changes in direction, every 25' on straight runs and at both sides of floor or wall penetrations.
- All fans shall be labeled as to use, area served and power source.
- All HVAC controls shall be of the direct digital type and conform to the controls design.
- All hydronic systems shall have adequate air eliminators installed.
- Provide 40-45% ASHRAE Dust Spot filtration in all major air handling units.
- All piping utilized for underground piping are required to have the ends sealed prior to storage or use on site. No end seals shall be removed until the end in question is ready for welding or otherwise connecting. In no event shall any piping be left in a trench with an open end at any time. This requirement shall be strictly enforced.
- Systems Test & Balance will be provided by the Contractor through the Architect/Engineer. The specifications will require the contractor to participate in the testing, make any changes necessary and pay for any re-testing that may be required to make the systems meet specifications.
- All air handling unit condensate drain pans must drain to the storm sewer system, with a by-pass to the floor drains when using chemicals to clean coils.
- Mechanical rooms shall not be utilized as return air plenums.
- Mechanical rooms that generate heat such as steam rooms and pump rooms shall be cooled using a thermostatically controlled forced air ventilation system utilizing outdoor air. Generally, pump rooms and similar spaces with electronic systems such as variable speed drives, shall be separated from rooms containing steam reducing stations and condensate pumps.
- All mechanical equipment such as air handlers, pumps, exhaust fans, etc., shall be referred to and labeled by floor number.

## Plumbing

- The Utility Provider will furnish water meters and taps for domestic and fire water. All tap fees and system charges shall be paid by the Contractor. Install water meters and domestic water backflow preventer above grade in an inconspicuous location and provide an insulated cover.
- Below grade, all domestic cold-water piping exterior to building shall be PVC.
- Underneath buildings, piping shall be type Schedule 80 CPVC, Cell Class 24448, with a 25 year manufacturers material warranty All domestic water piping inside the building and above grade shall be the same. Approved manufacturers are IPEX, GF and Nibco.
- Pressure reducing valves shall be set at 50 psig for potable water systems.
- Drain and dry all water systems after testing.
- Floor drains are to be provided in all toilet rooms, custodial closets, and mechanical rooms.
- All piping system strainers shall be equipped with valves for blowdown cleaning.

- Hose bibs shall be provided in any machinery rooms and at 100-foot intervals in exterior areas for maintenance use.
- Teflon containing joint sealer shall be utilized in all screwed piping installations.
- All piping shall be color coded and labeled as to use and flow direction.
- All exterior valves shall be fitted with a complete one-piece valve box unit constructed of concrete, steel, or plastic. The box shall have a hinged cover and be set in concrete. The installation shall be such to support small vehicle and lawn maintenance equipment.
- Urinals shall be of the flooded open throat type to avoid stoppages and odor problems. Urinals shall be provided with automatic flushing sensors.
- Floor drains, where necessary, are to be placed at the lowest point in the area and shall be provided in all restrooms, custodial closets, mechanical rooms, storage rooms, etc.
- Lavatory faucets shall be the types that will not flow over .5 GPM and provided with automatic sensors.
- Toilets shall be wall mounted and shall be provided with automatic flushing sensors.

### Water Base Fire Extinguishing Systems

- The fire system contractor shall furnish all labor and equipment for a complete installation of a water-based fire extinguishing system and shall be the installing contractor or site representative with the required license. No subcontracting is allowed. The contractor must be NICET level III certified and must possess the appropriate class I or class II fire sprinkler license as required by the State of Florida.
- Fire water-based systems shall be installed, inspected, tested, and certified per all appropriate Florida Building codes and NFPA standards, including NFPA 101.
- The fire system contractor shall be responsible for equipment, materials, and workmanship of the system for one year. The warranty shall be enforced 24 hours a day, seven days a week including weekends and holidays during this period. The contractor will also respond after being advised of their responsibility and the nature and/or condition of the equipment that has failed by the County within two hours of notification.
- Fire Flow backflow preventers shall be installed inside the building.
- The installation of fire water mains shall include backflow preventers.
- All fire mains and/or valves shall be painted and labeled to indicate the proper building name controls.
- Fire water system connections shall be compatible with the City of Tallahassee Fire Department fittings.
- Fire suppression systems shall be installed, tested, and certified per appropriate NFPA requirements.
- The main drains and inspectors test drains shall be pipe to an adequate drain inside or outside the building. When piped outside the building, the water flow shall not pose a threat to persons on sidewalks or streets adjacent to the building.

- Provide 3-1/2" gauges with a connection not smaller than 1/4", and each gauge connection equipped with a shutoff valve and provisions for draining.
- All control drains and test connection valves shall be provided with permanently marked weatherproof metal or rigid plastic identification signs. The sign shall be secured with corrosion-resistant wire, chain, or other approved means.
- All control valves will have proper signage to indicate the areas of coverage.
- This will start from the feed supply into the building through all branch lines.
- On any fire pump installation, the use of PVC and/or plastic pipe, fittings, or components will not be acceptable.

### Air Conditioning

- All air conditioning condensate lines shall be of insulated type "L" copper or approved equal. Provide insulation details to insure vapor proof covering.
- All chilled water piping shall be installed with shut-off valves at each floor and at each AHU.
- All major air handling unit coils shall be designed for not less than 15 degrees Fahrenheit temperature rises and be provided with two-way control valving.
- A/C Air Handling Units shall be double wall construction with a solid inner liner (no insulation exposed to airstream).
- Air Handling Units shall have fans mounted on internal vibration isolators (2" static deflection).
- Air Handling Units shall have double wall insulated drain pan.
- Air handling units installed in spaces exposed to outdoor air conditions (such as attics) must be sufficiently insulated to prevent surface condensation.
- Any controls or sensors such as humidistats shall be installed with remote indicators and control.

### Commissioning

- Commissioning processes will be determined on an individual project basis as deemed appropriate to meet the County's project requirements.
- All commissioning for HVAC systems shall be done in accordance with ASHRAE standard 202 and the Florida Building Code.

## Electrical Systems

### General Guidelines

- All utility metering must be coordinated with the County prior to completion of contract documents
- All electrical materials and equipment shall be UL or ETL listed.
- All materials and types of construction shall meet or exceed the requirements of UL, ANSI, NEMA, IEEE, and the NEC as well as conform to manufacturer's written recommendations. County staff shall be completely instructed in the operation and maintenance of installed equipment and systems.

- If the electric service for this project is existing, the sizes of the conduit, conductors and grounding system shown in these documents have been taken from prior construction documents, as built documents, limited inspection and with the assumption that this installation had been previously permitted, inspected and met the applicable building codes at the time of construction.
- Where in an existing older installation the ground and neutrals are terminated to the same grounding buss in existing panel boards, install a second grounding bus and separate neutral and grounding conductors to the appropriate and separate grounding bus.
- Prior to starting any new work, the electrical contractor shall open all panels, disconnect switches, wireways and inspect the portions of the electric service being reused and confirm the size and integrity of the existing installation.
- At the beginning of the project and for the duration of the project., the electrical contractor shall install the street numbers from the building address on all electric meters. Furthermore, it is the electrical contractor's responsibility to remind the General Contractor to do the same for the building.
- The contractor shall furnish all materials and labor necessary to provide for the installation of a complete electrical system.
- The contractor shall make a thorough examination of the site conditions and contract documents.
- The contractor shall coordinate metering, transformer and service connection requirements with the appropriate utilities.
- Provide any and all necessary temporary connections of equipment, devices or luminaires as may be required for construction.
- Provide an independent means of support for conduit installed above a ceiling where the supports are distinguishable by color, tagging or other effective means. The ceiling support system shall be permitted to support branch circuit wiring where installed in accordance with the ceiling manufacturer's instructions.
- Provide an insulated throat fitting or plastic bushing for all 1" & larger conduit terminations in panelboards, wireways and disconnect switches.
- Provide grounding bushings for any conduit terminations at eccentric and concentric knockouts in disconnects, panelboards & loadcenters or when reducing washers are used.
- Bond all junction and pull boxes to ground.
- Motor starting switches may be eliminated at duct heaters and vav boxes if a disconnecting means has been provided with the equipment.
- Install a full size neutral to all devices including switches.
- Terminate no more than one wire per terminal per NEC 110.14a.
- Conductors shall be twisted together prior to installation of wire nut.
- All boxes shall be a 4" square metal box with the appropriate ring. The maximum gap around any recessed box shall not exceed 1/8" and the maximum setback shall not exceed 1/4" per NEC 314.20 & 314.21.
- Verify door swings and back splash heights at rough in.

- Stagger back to back wall boxes in all walls by at least one stud.
- All conduit cut ends shall be reamed per NEC 358.28
- All exterior receptacles shall be weather resistant per NEC 406(d)6. At rough in, install Arlington "in box" where a heavy duty in use cover is required.
- Provide in use covers for electrical devices installed in damp and wet areas with the appropriate duty per NEC 406.9.
- Provide a typed panel schedule reflecting installed conditions for all panelboards with "space" or "spare" written in pencil.
- Install load centers and disconnects so that at least 3½ feet of working space can be maintained per NEC 110.26.
- Electrical equipment support wires shall be taut & fastened at both ends.
- Provide a disconnecting means for each water heater per FPC 504.3.
- Label all junction box covers with circuits designation contained within.
- Provide operating and installation instructions to the owner for all installed equipment.
- Provide the appropriate fire stop system and/or fire caulk at any penetration of a rated assembly.
- Penetrations of a rated horizontal assembly with a metal conduit not exceeding 6 inch nominal diameter, install concrete, grout, or mortar the full thickness of the floor as required by FBC 713.4.1.1 so to maintain the fire resistance rating. For multiple penetrations, refer to the FBC
- All junction boxes are to be accessible per NEC article 100.
- Conduit termination at NEMA 3R enclosures shall be with a myers hubs for top penetrations and liquid tight sealing rings or sealing locknuts for side penetrations.
- Install all plates so edges are flush with wall surface.
- For all led luminaires, mark each fixture with tag #, manufacturer, model number, installation date, installing contractor and length of warranty.
- Provide and install all necessary junction boxes, shown and not shown, that may be required for a complete and accessible code compliant installation.
- Install a box and support for a 70lb dynamic load at all ceiling fans and locations where a fan might be installed in the future.
- Where a conductor is too large to terminate to a breaker or disconnect, provide and install a step down compression adaptor or coupler reducer.
- Where threads are field cut, coat the threads with an approved corrosion resistant electrically conductive compound per NEC 300.6(a).
- Wall luminaires shall be installed after wall finishes have been applied.
- Strut installed above multiple panelboards shall be continuous in lieu of multiple short pieces.
- Provide HACR breakers for all hvac equipment.
- Provide GFCI breakers for drinking fountains.
- Provide as built drawings and a copy of approved shop drawings upon completion per Florida energy code C408.3.2.
- Provide blank plates for all unused boxes.



- Conduit and conductors to outdoor condensing units shall be underground or underslab rising to the appropriate condensing unit.
- Where four or more condensing units are installed adjacent to each other, a NEMA 3R panelboard with breakers shall be installed in lieu of individual disconnects.
- Where the electrical plans show the connection of an exhaust hood, additional direction of work to be completed by the electrical contractor will be found in the mechanical construction documents and shall be part of the base bid.
- The construction and installation of the primary electric conduit, transformer, transformer pad and metering are shown diagrammatic. The direction set forth by the local electric utility in its design manuals and specifications is applicable and becomes part of these construction documents.
- Provide a three way switch on both sides of double doors in electrical and mechanical rooms.

### Color Coding

- All conduit and MC cable shall be color coded as indicated. All external sides of each box and cover, a three inch wide band at least every 10 feet, and a 3” wide band not more than 12” from a wall penetration on each side.
- Normal branch – White
- Equipment branch – Green
- Life Safety Branch – Yellow
- Critical Branch – Orange
- Fire Alarm – Red
- Nurse Call – Purple
- Data – Blue
- Access Control – Gray
- Cameras and IPTV - Black

### Basic Material and Methods

- Conduit shall be EMT and fittings shall be steel. For underground and under slab installations, conduit shall be PVC or IMC w/an asphaltic coating. ENT or "smurf" tubing is not approved.
- Schedule 40 PVC is approved for use underground and under slab. Exterior lighting conduits shall be 1” minimum and buried to a depth called for by the NEC.
- PVC shall be converted to metallic where exposed to physical damage. Buried metallic conduit must have, minimum, two coats of bitumastic or have factory applied PVC coating.
- All empty conduits shall have a 200-pound test pull cord. Conduit shall be manufactured in the United States.
- Conduit shall be installed concealed, recessed and in a neat and workmanlike manner. All conduit shall be installed parallel or perpendicular to building lines.

- Exposed conduit on exterior walls of finished walls is prohibited.
- Seal all conduits where the conduit connects an interior conduit body to an exterior conduit body or luminaire.
- Underground PVC conduit shall be a least 12" under sidewalks, 24" under parking lots & driveways and 18" in all other locations per NEC 300.5.
- Provide sufficient spacing between buried conduits to allow appropriate compaction and heat dissipation.
- All underground conduits and conductors shall be marked with a detectable warning ribbon at least 12" above the conduit or conductor per NEC 300.5(d)(3).

## MC Cable

- The use of mc cable is allowed on this project subject to the limitations set forth below and according to parameters set forth in NEC70 article 330.
- MC cable can be used to connect luminaires installed within an accessible ceiling to a junction box when the length does not exceed six feet. In such installations, the MC cable fittings shall be permitted as means of cable support.
- MC cable can be used to connect devices installed concealed inside a wall cavity.
- MC cable can be used to connect the last device in a circuit to a homerun junction box mounted on or adjacent to the framing top plate.
- MC cable use shall be limited to #12 and #10 copper conductors.
- MC cable shall be installed parallel or perpendicular to building lines and framing members.
- MC cable shall be used for branch circuits only. Homeruns shall be in conduit.
- MC cable shall be protected when installed through or run parallel to framing members so that the nearest outside surface is at least 1 1/4" from the nearest edge of the framing member. When this distance cannot be maintained, the cable shall be protected from screw or nail penetration by a steel plate, sleeve or equivalent of at least 1/16" thick.
- The radius of inner bend in corrugated sheath MC cable shall be greater than 4" for MC cable containing #12 conductors and 4.5" for MC cable containing #10 conductors.
- MC cables shall be supported at least every 6' & within 12" of every box, fitting or other termination.
- MC cable shall be replaced when the corrugated sheath has separated and is no longer interlocked.
- Medical grade MC cable shall be used in patient care areas but not in business offices, corridors, lounges, waiting rooms and similar areas per 517.10(b).
- MC luminary cable shall be used when connecting a dimming device to a dimmable luminaire.

## Wires and Cables

- All conductors shall be sized for maximum total 5% voltage drop from service to device.
- All conductors shall be copper, type THHN/THWN.
- Minimum conductor size is #12AWG.
- Aluminum, type XHHW or THWN, may be used for service feeder conductors.

## Panelboards

- Panelboards shall be identified using permanently attached machine engraved phenolic nameplates.
- Standard color shall be white letters on black background. Emergency panels shall have white letters on a red background. Panelboard busses shall be copper. Lighting and receptacle panelboard neutral busses shall be rated 100%. Panelboards shall be sized with a minimum of 20% spare spaces.
- Switchboards, switchgear and motor control centers shall be provided with 25% spare space.
- Circuit breakers shall be bolt-on construction. Overcurrent devices shall be rated for the calculated available bolted short circuit fault currents.
- Each panel board and disconnecting means shall be marked to indicate its purpose, feed, and of sufficient durability to withstand the environment involved per NEC 110.22.
- A listed SPD shall be installed in each panelboard.

## Switches and Receptacles

- Switches and receptacles shall be specification grade and rated 20 amperes.
- Provide a receptacle with GFCI protection and heavy duty in use cover adjacent to the exterior service entrance equipment
- Standard color shall be white. In stone walls, devices shall be ivory and devices in dark millwork shall be brown.
- Limit multiple ganged device installation to three gangs.
- Where a two pole occupancy sensor or multiple switches are installed, the button or switch closest to the door shall operate the light of the room being entered.
- In offices at each desk, provide a quad receptacle under the desk and an USB receptacle above the desk.
- Device plates shall match device color except install stainless steel in all janitor closets and food service areas.
- Maintain course spacing for installation of devices. Switches are at 48" top of box and receptacles and data are installed at 16" bottom of box. High use receptacles may be raised to 36".
- Devices assigned to the emergency system shall be red in color unless another color code has already been established in an existing facility.

- Receptacles installed within 6' of water source shall be GFCI regardless of plan designation. Coordinate installation of receptacles shown adjacent to millwork with architectural elevations so they are accessible. Locations shown on plan are diagrammatic.
- Dimmable occupancy sensors shall be used for lighting systems in office spaces.
- Vending machines and refrigerators shall have receptacles installed at 36" bottom of box.
- Hallways shall have receptacles installed 50 feet on center, maximum and not more than 25' from the corridor end.
- Outlets shall be provided on the exterior of facilities so that a weather resistant receptacle installed in a heavy duty in-use cover and located not more than 25' from all mechanical equipment, the service entrance and any cleanout.
- Floor outlets shall be flush with finished floor or floor covering, as applicable.
- When required for conference rooms or other spaces, receptacles for overhead LCD projector shall be mounted flush with ceiling.

### Motors and Starters

- Motors shall be high efficiency and have an operating power factor of 90% or greater.
- Provide reduced voltage starters or variable speed drives for all motors, 15 horsepower, or larger.

### Service and Distribution

- Service to buildings shall be supplied with pad-mounted transformers as described below. The transformers, service entrance conductors or bus, and main electrical panel or equipment shall be of adequate size for the demand expected in the facility and to allow for future growth of 25% based on calculated diversified demand.
- Transformers shall be located as close as possible to the main electric service room. Future servicing or replacement of transformers shall be a consideration when selecting a location. The transformer shall be protected from vehicular and pedestrian traffic.
- The location of the building electric service apparatus shall be incorporated in the landscaping as much as possible.
- All grounding for building services, standby generators, and transformers shall achieve a maximum 25ohm reading using the three-point test method. Multiple rods shall be driven to achieve the 25-ohm reading, if necessary. All grounds shall be connected with a properly sized copper conductor. All ground bus shall be connected to ground rods by an approved exothermic welding process.
- The minimum grounding system shall be a 20' triad installed 10' apart with exothermic connection.
- Medium-Voltage Transformers: Factory assembled and tested, general purpose, air-cooled, liquid filled as indicated, and having characteristics and capacities as indicated, designed for operation with high-voltage windings connected to a 3-phase, 3-wire, 60 Hz, system.

- Transformer windings may be either copper or aluminum.

## Emergency Power Supply System

### General Conditions

- Where required and/or for continuity of function in certain facilities identified by the County, provide a standby rated emergency power generator set, EPS. Emergency lighting and directional signage shall be battery-backup and powered by the standby generator.
- On the construction documents, the EPS shall be defined as legally required or optional. Furthermore, the Class, Type and Level should also be clearly defined. The minimum class is 24 and the maximum Type is 10.
- Engine generator set shall be diesel fueled. Natural gas and LP fueled sets are acceptable.
- Fuel tanks shall be an above ground storage tank meeting the requirements of Chapter 62-762, Florida Administrative Code. It shall not be installed within 100 feet of water well, provided with secondary tanks containment with tanks fill spill containment and with a method to detect a release from any portion of the storage tank system.
- The EPS shall be started electrically using its own properly rated and sized batteries. Air start is unacceptable.
- Engine generator set shall connect to building power distribution system through coil and contactor operated automatic transfer switches. “Walking Beam” switches are unacceptable except for City of Tallahassee plumbing lift stations. Transfer switch shall have an integral, field adjustable automatic exerciser clock.
- Generator shall conform to ISO-9001; have Class H insulation, and permanent magnet excitation for production of sufficient current under fault conditions to allow downstream phase over-current coordination.
- Generator set on-site acceptance testing shall be performed in accordance with NFPA-110 with a two hour full load test at 100% power factor. Leon County Facilities personnel shall be notified of the test schedule so that they may attend. Equipment supplier shall supply two operations and maintenance manuals.
- Generator set shall be cooled with self-contained coolant and radiator system. Remote radiators are unacceptable.
- Unit shall be located and physically protected in a rated sound attenuated enclosure.
- Caterpillar, Cummins and Generac are the only approved manufacturers.
- All conductors terminated at the EPS shall be stranded and terminated with at least one bend to allow three dimensional motion.
- Install an EPO within site of the EPS.
- Place a sign at the main service entrance indicating the location and type of the EPS.
- All boxes and enclosures for emergency circuits shall be permanently marked as a component of the EPSS. Raceways shall be marked every 25 feet.
- Remote annunciator should be shown on drawings, generally located at the reception area.

- Emergency lighting should be provided in ATS/electrical rooms and fed from the life safety circuit.
- Provide breaker space for the generator shunt trip circuit.
- Generation equipment shall not be installed in Electrical rooms and must be at least 15 feet clear of any openings to Electrical rooms.
- The exhaust outlet of Customer-owned generators must be at least 15 feet from all power equipment because heat, noise and exhaust fumes.
- All generators and automatic transfer switches shall have a five-year warranty.

## Special Systems

- Expansions of existing facilities shall upgrade the existing lightning protection system as required.
- The building shall be tested to confirm it meets the requirements set forth by NFPA 1221 for the Emergency radio communication system by FSS 633.202.

## EV Charging Installations

- See Installation details at the end of the guidelines.
- The .dwg file is available for use by the design professional.
- The contractor shall provide the conduit, conductors, concrete pedestal, junction box and breakers per detail.
- Maintenance will set the dowels, install conduit extension, pull in the conductors and set the EV charging equipment.
- Provide one charging station set between a regular parking space and an accessible charging space per detail. The accessible charging space IS NOT to be a required ADA accessible space.

## Interior Lighting

- All lighting designs shall comply with the current edition of the Illuminating Engineers Society (IES) standard
- All interior luminaires shall be LED with a 4000°K temperature.
- A light level of 10FC is required on the middle tread of each set of stairs. Install a two wall mounted luminaires per landing on opposite sides and centered on the edge of the landing.
- Emergency lighting with battery backup shall be provided on both sides of egress doors and at all other locations as required by the Florida Building Code and shall be powered from the building emergency generator system when provided.
- Install emergency lighting in all break rooms and restrooms.
- Install 2'x2' LED luminaires 10' on centers in corridors.
- If possible, no lights shall be installed that require scaffolding for re-lamping.
- Exit lights shall be of the Light Emitting Diode (LED) type.
- In classrooms and offices, provide 30 – 50 FC at desktop.
- Install luminaires with battery test switches with the test button down.
- Install exit lights 2" above the top of the door jamb. the door jamb.

- Luminaires installed in suspended ceilings shall be fastened to the ceiling framing members with listed clips in accordance with NEC 410.36(b).
- Use a LLF of 0.95 for interior lighting calculation.
- Where a luminaire is installed mounted to a box, install a box and support rated for a 50lb static load. Such luminaires include but are not limited to exit lights, egress lighting, wall pacs & wall mounted strips.
- Exit lights shall be green.
- Exit and egress lighting shall always be installed to the wall and not an ACT ceiling.
- Luminaire schedules should have a column for weight and a column indicating mounting height.
- Separate wires supporting luminaires are not desired by TFD.

### Exterior Lighting

- All exterior luminaires shall be LED with a 3000°K temperature and full cutoff distribution.
- For open parking areas, the maintained horizontal illuminance shall be an average of 1FC with a minimum of .5 FC while maintain an average to min uniformity ratio of 4:1.
- When outdoor lighting is associated with a building project, security lighting and parking lot lighting shall be included in the building design.
- Pole mounted parking lot luminaires shall be installed at a 25' mounting height and spaced at four times the mounting height.
- Building mounted luminaires shall be installed at 12' above grade.
- Walkway and exterior security lighting shall be controlled by a photoelectric cell and contactor, with a manual override for maintenance.
- Use a LLF of 0.92 for exterior lighting.  
Coordinate with landscape designer location of light poles. Light poles have the priority over tree locations.
- Establish lighting control schedule for dusk to dawn operation where light levels are dimmed until motion is detected.

# Drawings & Details

## Electrical Rooms

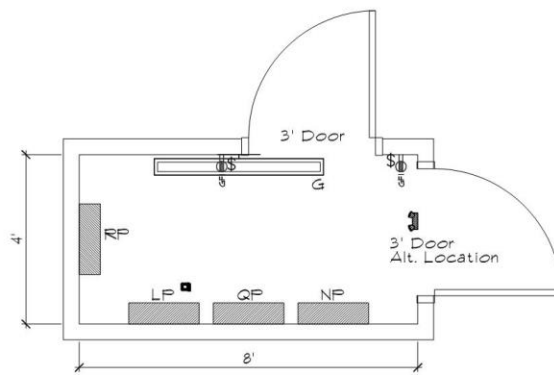
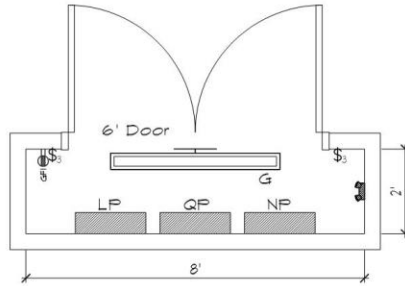

**ME MEDIUM ELECTRICAL ROOM**  
SCALE: NOT TO SCALE

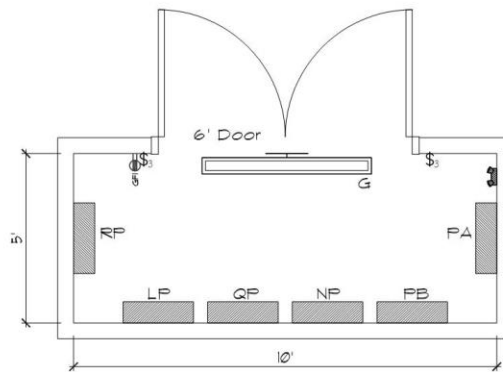

**LE LARGE ELECTRICAL ROOM**  
SCALE: NOT TO SCALE



# Data Rooms

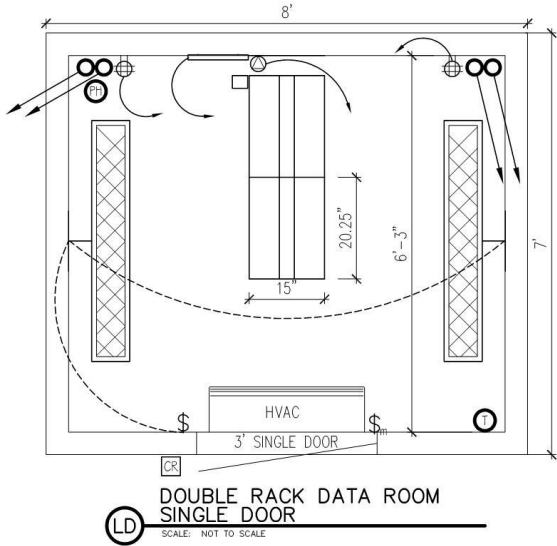
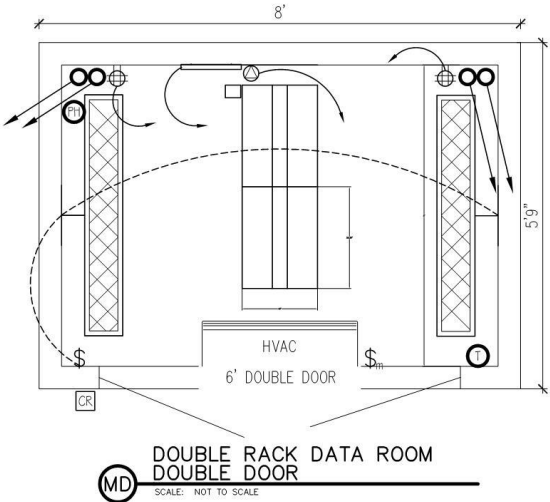
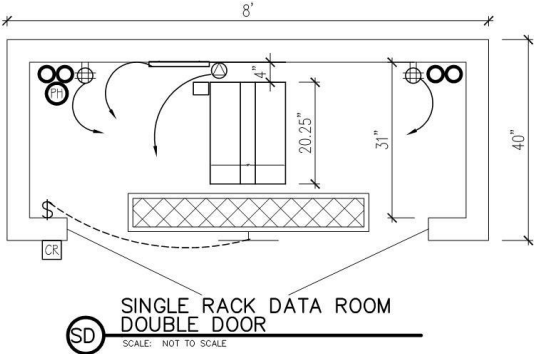



# EV Charging Station Details

## Elevation of Contractor Installation

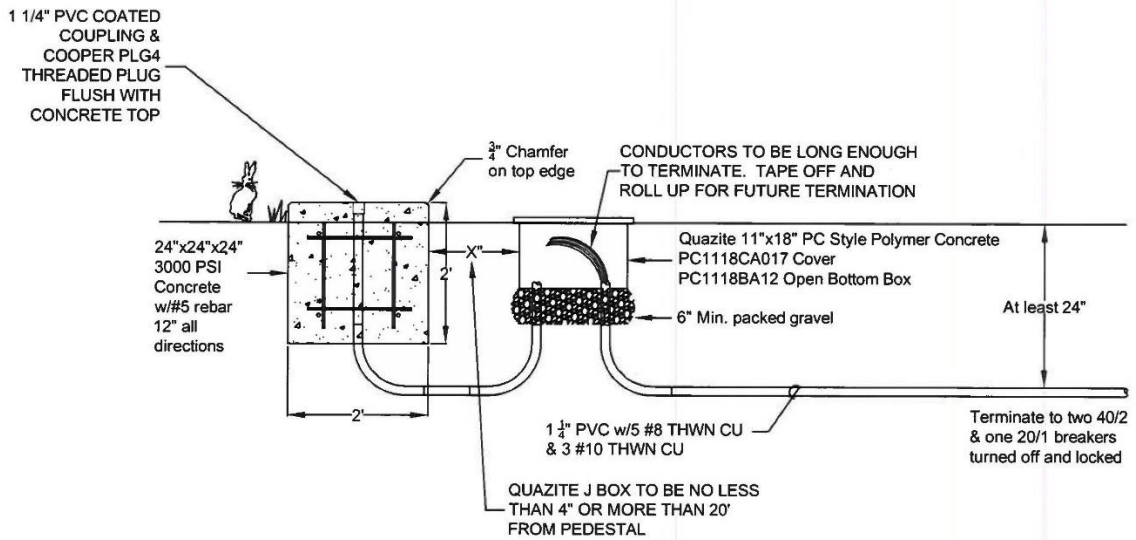

## INSTALLATION DETAIL - WITH JUNCTION BOX

### Plan View of Pedestal

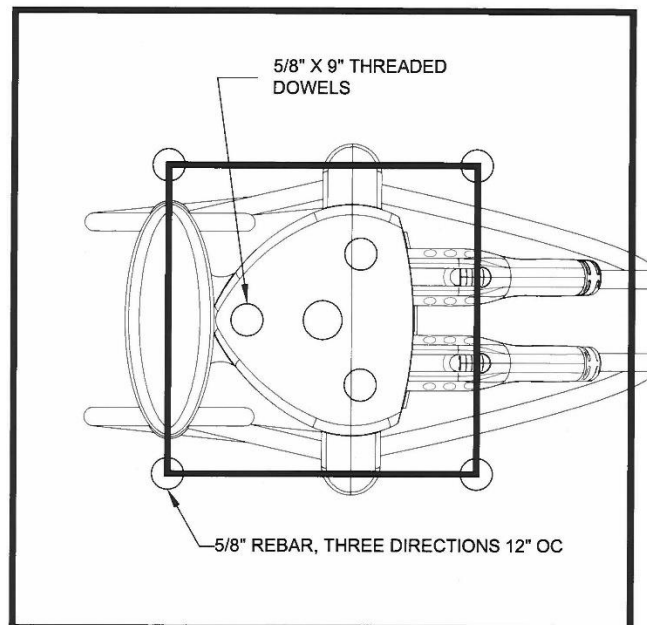

## PLAN VIEW

Maintenance Installed Detail

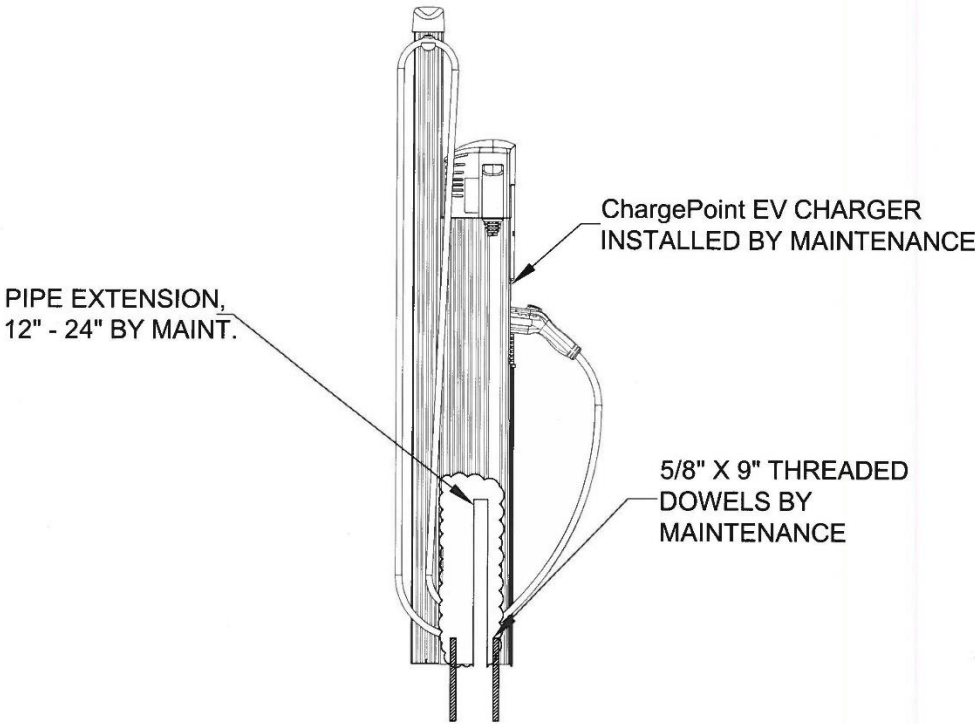

EV Charging Parking Space Detail

